

Discover new Possibilities



SCHEDULE

Samaya

SMART SCHEDULERS

Product Brochure

Do you have a need to schedule your pumps, venturi remotely?
Do you want to know if the device got turned ON/OFF?
Do you want to be free from uncertainty of Power Availability?

Sasya introduces connected scheduler – **Samaya** for complex scheduling requirements of devices (pumps, venturi, valves) for farms & Greenhouses. **Samaya** schedulers can be configured easily by experts remotely. Multiple devices can be scheduled in a given order and can be activated and tracked on Sasya IoT platform.

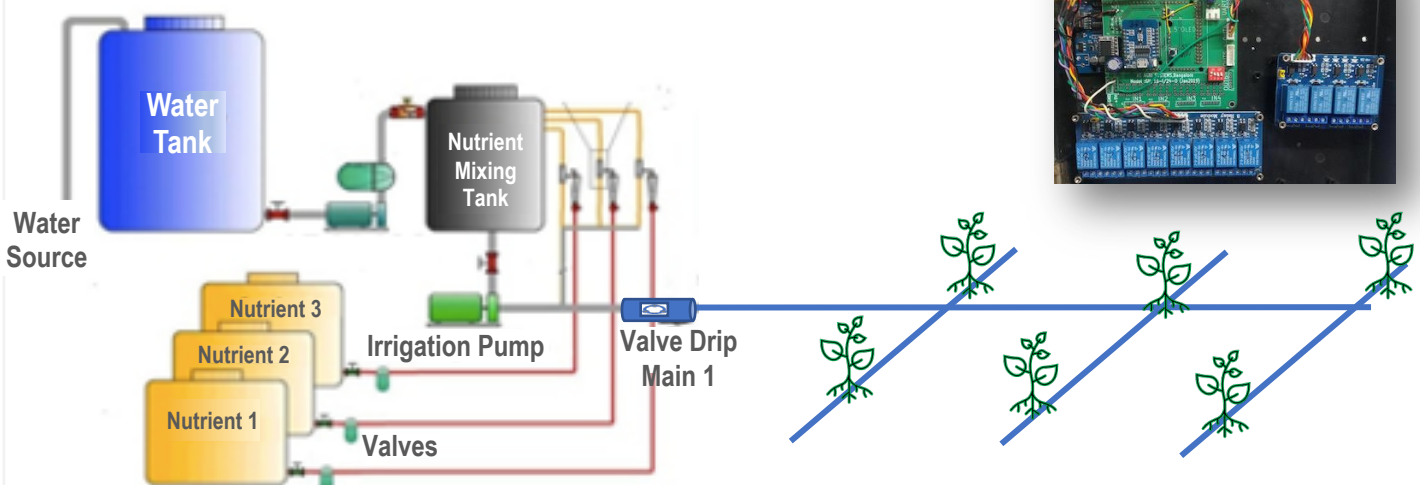
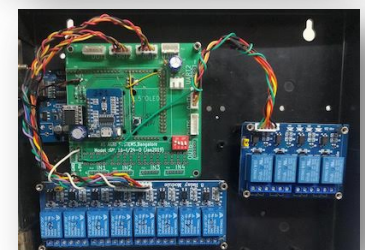

Fit **Samaya** and forget about issues with your Device Scheduling and monitoring 24X7 remotely and even in case of unpredictable power supply

Smart Scheduler Samaya



Connected Schedulers for complex device management

Highlights



Total 100 schedules can be set for a day.
Basic Model 12 channel can be extended to 24 Channels (Relays) for Devices



Each Channel can be programmed independently, and has Manual ON/OFF



Incase of power failure remaining program will run when power resumes.



Wifi connected, can be programmed, monitored and troubleshoot remotely.
Programmed with Mobile or Computer

Benefits

Where Best suited for Open field multi zone irrigation & fertigation nutrient valve, Hydroponic GH valves etc.

Why 30% Saving of manual labour in farm monitoring & controlling activities

With Retro-fitment in existing panels, pumps for automation

And Zero Recurring cost* for solution usage

*Conditions Apply



www.sasyasystems.com | SASYA SYSTEMS | IoT Sense-Monitor-Automate
426, 9th Main, 23rd Cross, HSR Layout, Sector 7, Bangalore 560102



santosh@sasyasystems.com | +91 8197239206

© 2021 Sasya Systems. All Rights Reserved. This document is a sole property of Sasya Systems. Bangalore, India. No part of this document be copied or reproduced without approval of Sasya Systems.